

AIRTECH

CLEAN BOOTH 潔淨操作棚

Economical · Customized · Exclusive dust-free working space

Cleanliness level ISO3~ISO8

ACB-021030TF-1K

1 Energy saving

Change the direction of the wind, to improve the efficiency of the motor and achieve energy-saving effects.

2 Anti-static curtain

High transparency and good flexibility.



3 Control system

Intuitively monitor system status.

ISO-14644

Cleanliness level

The cleanliness level of ISO3 ~ISO8 can be customized.

Anti-static curtain (board)

There are special coatings on the surface to prevent dust from adhering to the curtain.

Monitoring system

Equipped with a high-tech single chip communication control box to meet the monitoring requirements of the entire field. HMI can be installed to control the status of the equipment at any time.

UV light Optional

Drawing

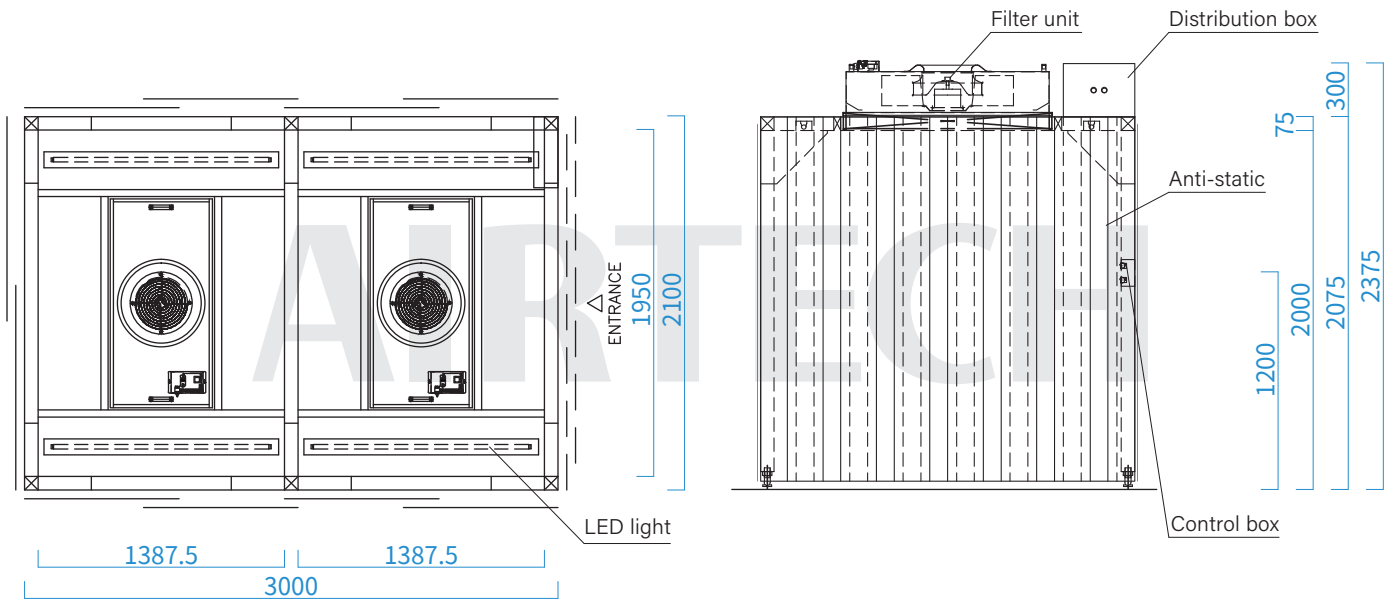

Note: The product is customized according to the special specifications specified by the customer.

Specification

Model	ACB-021030TF-1K		
Cleanliness	ISO Class 6(Class 1000 (US. FED STD. 209D))		
Particle Efficiency	Above 99.99% Efficient On 0.3µm Particles		
Main filter	HEPA Filter x 2pcs		
Operating speed	High	Medium	Low
Air Velocity(m/sec)	0.46	0.38	0.31
Air Volume(CMM)	34	28	23
Air exchange rate	161	133	109
Structure	Aluminum extrusion structure/cold -rolled steel plate baking paint		
Electrical	AC220 1Φ50/60Hz		
Light	LED 20W x 4 set		
Power Consumption(VA)	450	400	390
Optional	PVC antistatic board, explosion proof type of the whole machines, MPU joint control device.		