

AIRTECH

HAND DRYER 雙風刀 with WASHER 洗手烘乾機

Fully automatic · High efficiency · Double air knife design

NEW

AHD-145DW-DC

1 Using high-efficiency HEPA filter

Equipped with a high-efficiency filter, which can remove particles above $0.3 \mu\text{m}$.

2 Photoelectric sensor

Full proof device driven by dual sensors.

3 Reduce noise

Patented air duct, matched with highly efficiency blower, so that the noise will be highly reduced.



4 Double air knife design

Exclusively double air knife design, it improves motor efficiency and achieve the energy saving effect.

5 Punching plate

Prevents for water splashing and blockage by foreign objects, it is also convenient for assemble and dis-assemble and easy to clean.

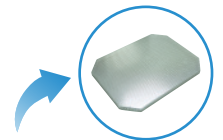

Step flow

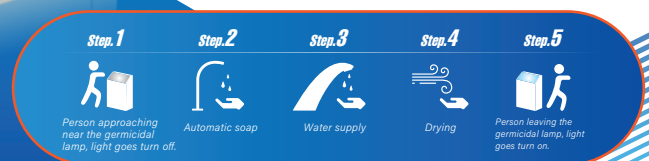

DC brushless motor

Non-maintenance, long life, brushless motor does not produce toner.



Can be equipped with cosmetic mirror

Optional

Intimate plastic surgery mirror design, convenient for users to tidy up their clothes and appearances.



Double air knife design

Adopting a new upper and lower air knife design, which can effectively shorten the drying time at a wind speed of 145m/sec.



UV lamp

The germicidal lamp can effectively prevent the reproduction of miscellaneous bacteria and is activated when the person leaves the sensor.

Drawing

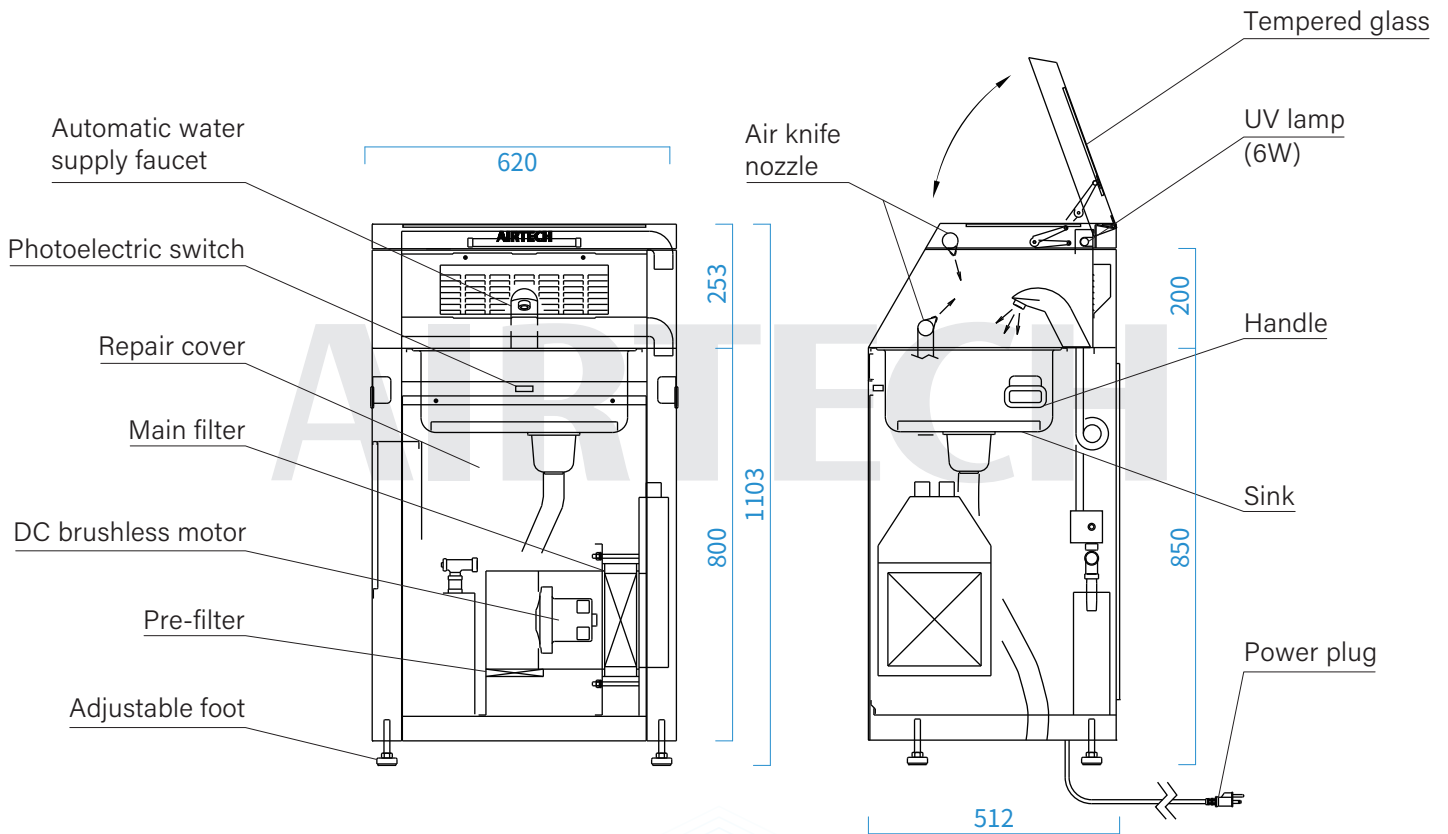

Specification

Model	AHD-145DW-DC	
Particle Efficiency	Above 99.99% Efficient On 0.3 μ m Particles	
Dust Collection	HEPA filter	
Air Volume(m ³ /min)	1.67 \pm 20%	
Air Velocity(m/s)	145 \pm 20%	
Air knife form	Double air knife	
Power Consumption(VA)	1350	
Electrical	AC110V 1 Φ 50/60Hz	
Dimension(WxDxH)(mm)	620x505x1103	
Weight(kg)	65	
Structure	Main body	Steel plate baked paint / SUS 304
	Sink	SUS 304
Optional	Cosmetic mirror 、 Heater 、 immersion 5 μ m water filter irrigation	